

Development of Stock Market Prediction Mobile System in Blue Chip Stocks for Malaysia Share Market Using Deep Learning Technique

Chong Fong Kim^{1*}, Yong Sik Tian¹, Yap Choi Sen¹

¹Faculty of Information Technology, INTI International University, Persiaran Perdana BBN, Putra Nilai, 71800 Negeri Sembilan, Malaysia.

*Email: fongkim.chong@newinti.edu.my

Abstract

Bursa Malaysia is the stock market of Malaysia where the exchange is tracked by the Kuala Lumpur Composite Index (KLCI) and blue chip stocks are the stocks trading in KLCI as well. Blue chip stocks are stocks issued by well-established and market capitalization firms, which have a sound financial performance for an extended period. There are various techniques investors use in the stock market investment; some may use fundamental analysis, technical analysis, emotion influence or even gambling technique. None of the mentioned techniques guarantee of 100% profit in stock market, which because of low accuracy analysis, lack of knowledge with no proper study on the stock, casino mentality in the stock market or even with no proper investment goal. Most of the Malaysian is not interested to invest in the stock market due to risk of losing money. This paper will look into the use of deep learning technique in developing a stock prediction system in mobile android platform with the features of predicting and recommending stock price mainly for blue chip stock in Malaysia Stock Market. Therefore, the objective of this paper is to look into the used of Long-Short Term Memory (LSTM), one of the deep learning technique applied in the prototype system, which to improve the accuracy of forecasting in stock market in term of stock price prediction and the recommendation of the buy or sell mode for the 30 samples blue chip stocks. According to Isah and Zulkermine (2019), the accuracy of stock prediction is about 72% to 85% and the prediction can be made successfully with LSTM (Seyda, Akhtar, etc. 2020).

Keywords

Predictive Analytics, Long-Short Term Memory (LSTM), Deep Learning

Introduction

In Malaysia, there are many investment areas available and share market investment is one of them. However, investing in stock market can be very challenging for the investors, as they might not know when will be the right timing in buy in or sell out the share. According to article from Lee (2015), Malaysian investors will just keep their stocks even though it is losing 20% to 30% of their investment because they hope one day the thing will change, which eventually losing more



than they expected in the market. There is no guideline to tell these investors the period to cut-down their loss. Another reason is that Malaysian investors are still lacking in financial knowledge. A statement made by the YB Khairy Jamaluddin about the investors is that investors do not have sufficient knowledge in investing in stock market. (Jay, 2017). Investors who lack of financial knowledge will not able to analyze the risk management and the structure of the portfolio. Emotion Market is also one of the reasons why investors lose money. The fear of missing out a bull market happened in many investors, which will result in selling low or buying high. This kind of investment strategy will make the investors to lose more money and eventually demotivated them and leave the share market.

This paper will look into the use of deep learning technique in developing a mobile stock market prediction system, where this system will predict the future price of a stock based on historical prices and the financial news. The authors used deep learning techniques in training the historical dataset and the financial news to analyze the stock price pattern, the confidence of the predicted stock price and the market sentiment. Long-Short Term Memory (LSTM) is the technique of deep learning which used in the proposed system and is recognize as a good technique when come to predict the stock price.

Methodology

This section describes the research methodology designed and implemented towards the development of the proposed system in this paper.

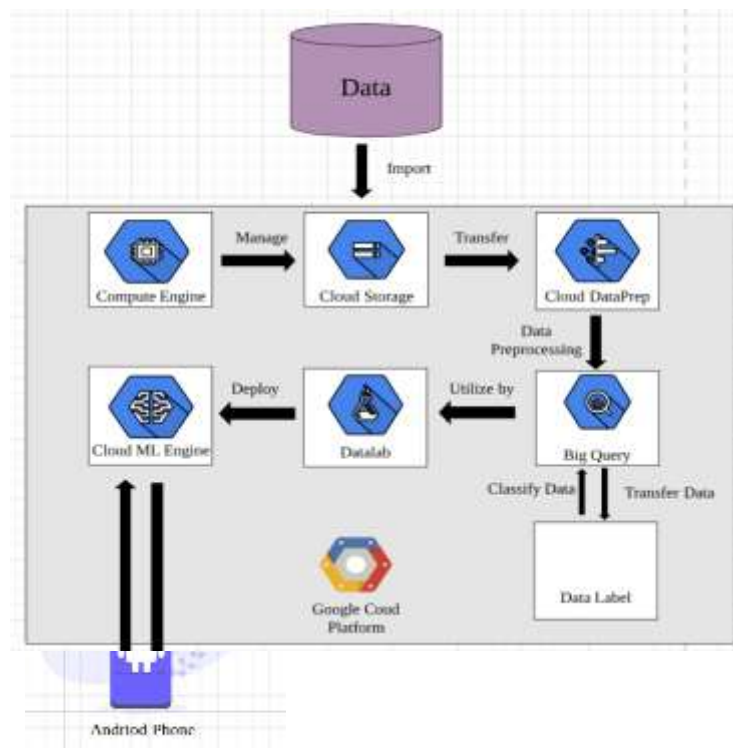

Figure 1. Research Methodology

Figure 1 shows the backend architecture of the proposed system. Google Cloud Platform used in this system as a supportive channel where this platform provides a variety of services for the

development of the system especially in data processing. The following describes the steps in the backend architecture of the proposed system:

- 1) Compute Engine was used in creating a virtual machine in order to manage datasets from various sources, and then the data will be stored in Cloud Storage before transfer to Cloud DataPrep to perform ETL (Extract, Transfer and Load) process mainly for data preprocessing and data cleansing.
- 2) In Cloud DataPrep, the data was transformed to a format or structure, which was suitable to a trained data where these data are stored in a component called BigQuery.
- 3) Then, the data will be imported from the BigQuery into Datalab for training and testing purpose. Python code will be used to perform the algorithm training and testing on the data before extracted and deployed to Cloud ML Engine.
- 4) At last, the result of the training data will be deployed to Cloud ML Engine and this is the place where it serve as a connection with the android system and also sending the result to application.

Results and Discussion

Stock market prices are highly unpredictable and volatile where there are no consistent patterns in the data, which can be model the stock prices over time perfectly. According to the researched by Seyda (2020), deep learning-based approaches have shown a promising accuracy in stock data classification. There are few researches showed LSTM model in deep learning has the ability to deal with sequential data and most suitable for training and testing the stock market value prediction. For example, Chen, Zhou and Dai (2015) used this model in Chinese stock market data where they used historical price data of market indices and stocks; Li, Bu and Wu (2017) also used LSTM to estimate investor shares and end up concluded that this model give better results in price prediction. The outcome of a prediction study conducted by David M. Q. Nelson and his friends (2017) also concluded that the model was more successful in predicting high variations, which can achieved an average accuracy of 55.90%. LSTM model (figure 2) is a powerful time-series model which it can predict an arbitrary number of steps in the future. This model will take historical stock prices values and financial news as input to predict the price trends and also can be deployed to predict if a stock price will go up, down or stay the same on the day or for future few days.

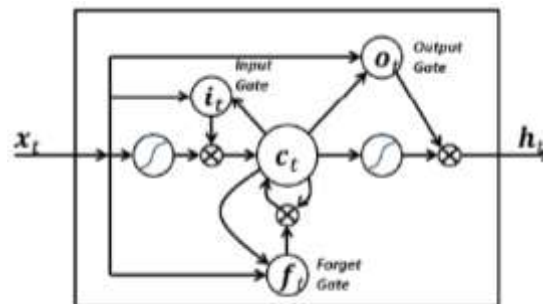

Figure 2. Long-Short Term Memory model
(K. Greff, R. K. Srivastava, J. Koutn'ík, B. R. Steunebrink, and J. Schmidhuber, 2015)

The authors has created a prototype of stock market prediction system in mobile version to demonstrate the level of accuracy using the LSTM model for the stock value prediction of 30 blue-chips stocks in Bursa Malaysia.

The following figure 3, 4 and 5 are some samples of the screen-shots generated from the proposed system, which used LSTM model to predict the future stock prices for three of the blue-chips stocks in Bursa Malaysia like Airport (figure 3), Maxis (figure 4) and IOICorp (figure 5). The graphic created shows the predicted stock price for the future 1, 3 or 7 days.



Figure 3. Stock Prediction future value for Airport

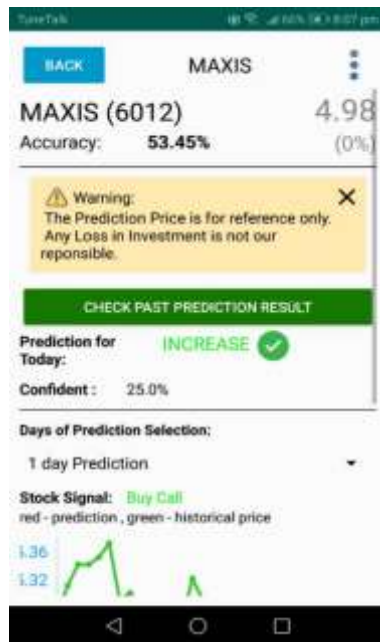

Figure 4. Stock Prediction future value for Maxis



Figure 5. Stock Prediction value for IOICorp

Figure 6, 7 and 8 shows the accuracy level of the predicted stock value for the above mentioned three stocks. The author used confident calculation script to determine how likely the prediction result happen by using past historical stock price trend result. All the stock prices will be classified as increased, decreased or maintained by comparing the prices from yesterday. In this way, the confident percentage that is the accuracy level of predicted stock price can be calculated to know how likely the predicted prices is close to the real values. The accuracy level for the proposed system is somewhere 50% to 60%, however according to Isah and Zulkermine (2019), the accuracy of stock prediction using LSTM is about 72% to 85%. Therefore, the accuracy level of the proposed system is still not reaching the benchmark and there are still many improvements need to be done to the proposed system.



Figure 6. Accuracy level for Airport stock



Figure 7. Accuracy level for Maxis stock



Figure 8. Accuracy level for IOICorp stock

In recent years, there are various methods based on deep learning like SVM, RNN and other algorithms that are also use in predicting stock price. Sufficient and current dataset will most likely to increase the accuracy rate. The proposed system provides a prototype to estimate the closing price of the three popular stocks traded on Bursa Malaysia. The accuracy of prediction result produced from the system is around 50% to 60% based on the historical stock values indices, which also matched to the findings of the researches. The accuracy of the stock prediction value is largely influence by the factors like the stocks financial performance, stakeholder changing, and volume of the trade and also because of the economic and political stability of the country. However, the model LSTM provides quite promising result in stock price prediction.

Acknowledgements

We would like to thanks INTI International University provides us the opportunity in presenting our research in ICIT2020 and accepted our paper in INTI Journal Publication. We would also like to show our gratitude to ICIT2020 Conference committee especially the reviewer of this paper for his or her comments given in this paper.

References

- Beatrice Nita Jay (13 October 2017), “Young Malaysians lacking in financial knowledge, need to start investing”. Retrieved from <https://www.nst.com.my/news/nation/2017/10/290665/young->
- D. M. Q. Nelson, A. C. M. Pereira, and R. A. De Oliveira, “Stock market’s price movement prediction with LSTM neural networks,” Proc. Int. Jt. Conf. Neural Networks, vol. 2017-May, no. Dcc, pp. 1419–1426, 2017, doi: 10.1109/IJCNN.2017.7966019.
- Expat Inc.. 2019. Market Sensei Launches Machine Learning-Powered Stock Market Prediction Platform for Novice and Experienced Investors. [ONLINE] Available at: <https://www.prnewswire.com/news-releases/market-sensei-launches-machine-learning-powered-stock-market-prediction-platform-for-novice-and-experienced-investors-300512043.html>. [Accessed 23 August 2020].
- Iris Lee (29 September 2015), “5 Common Reasons Why The Malaysian Middle Class Can’t Achieve Financial Freedom”, Retrieved from <https://www.imoney.my/articles/5-common-reasons-why-the-malaysian-middle-class-cant-achieve-financial-freedom>
- Isah, H., 2019. Stock Market Analysis: A Review and Taxonomy of Prediction Techniques. 1. Canada: Queen's University. [ONLINE] Available at: <https://www.mdpi.com/2227-7072/7/2/26> [Assessed 10 August 2020]
- J. Li, H. Bu, and J. Wu, “Sentiment-aware stock market prediction: A deep learning method,” 14th Int. Conf. Serv. Syst. Serv. Manag. ICSSSM 2017 - Proc., 2017, doi: 10.1109/ICSSSM.2017.7996306.
- K. Chen, Y. Zhou, and F. Dai, “A LSTM-based method for stock returns prediction: A case study of China stock market,” Proc. - 2015 IEEE Int. Conf. Big Data, IEEE Big Data 2015, pp. 2823–2824, 2015, doi: 10.1109/BigData.2015.7364089.
- MarketWatch. 2019. Deep Learning Algorithms Now Predict Different Asset Classes with Extraordinary Accuracy - MarketWatch. [ONLINE] Available at: <https://www.marketwatch.com/press-release/deep-learning-algorithms-now-predict-different-asset-classes-with-extraordinary-accuracy-2019-09-09>. [Accessed 13 August 2020].
- Seyda Kalyoncu*1, Akhtar Jamil1, Enes Karatas1, Jawad Rasheed1, Chawki Djeddi2, “Stock Market Value Prediction using Deep Learning”, 3rd International Conference on Data Science and Applications (ICONDATA’20), June 25-28, 2020, Istanbul, TURKEY.