

## Implementation of DC-to-DC Isolated Converter by Using dpa425r for EV Drive

M. Maria Roshan<sup>1\*</sup>, D. Lakshmi<sup>2</sup>, V. Antony Sahaya Anand<sup>3</sup>

<sup>1,2,3</sup>Department of EEE, AMET Deemed to be University, Kanathur, India

**Email:** aec22038@ametuniv.ac.in<sup>1\*</sup>, lakshmi.d@ametuniv.ac.in<sup>2</sup>

### Abstract

Electric vehicle (EV) auxiliary systems require compact and efficient isolated DC–DC converters to power low-voltage electronics from intermediate DC buses. This paper presents the implementation of a 30 W isolated forward DC–DC converter using the DPA425R integrated switcher IC for EV auxiliary applications. The converter operates over a 36–75 V DC input range and provides a regulated 5 V isolated output suitable for battery management systems, sensors, and communication modules. The proposed design utilizes the integrated MOSFET, pulse-width modulation control, soft-start operation, thermal shutdown, undervoltage protection, and auto-restart features of the DPA425R to improve reliability under EV operating conditions. Mathematical modelling is incorporated for transformer and output-stage design. Simulation and experimental validation demonstrate output voltage regulation within  $\pm 2\%$ , output ripple below 50 mV, and peak efficiency of approximately 88%. Comparative analysis with conventional flyback converters shows improved efficiency, reduced ripple, and better thermal performance. The proposed converter therefore provides a compact and reliable auxiliary power solution for EV applications.

### Keywords

Electric vehicle, DC–DC converter, DPA425R, forward converter, auxiliary supply

### Introduction

Electric vehicles (EVs) contain multiple electronic subsystems such as battery management systems, communication modules, controllers, and sensors operating at different voltage levels. These systems require compact and isolated low-voltage power supplies derived from the main battery or intermediate DC bus. Therefore, isolated DC–DC converters are important components in EV auxiliary power architectures.

Conventional isolated converters using discrete switching devices require multiple external components including MOSFET drivers, startup circuits, and protection networks. These increase circuit complexity, electromagnetic interference, thermal stress, and PCB area. To overcome these limitations, integrated converter ICs combining switching and protection functions in a single package have gained importance.

**Submission:** 14 April 2026; **Acceptance:** 11 May 2026; **Available online:** May 2026



**Copyright:** © 2026. All the authors listed in this paper. The distribution, reproduction, and any other usage of the content of this paper is permitted, with credit given to all the author(s) and copyright owner(s) in accordance to common academic practice. This article is an open access article distributed under the terms and conditions of the Creative Commons Attribution (CC BY) license, as stated in the website: <https://creativecommons.org/licenses/by/4.0/>

Power Integrations introduced the DPA-Switch family for compact isolated DC–DC converter implementation. Previous studies mainly focus on flyback converters and stationary power systems. However, limited work has been reported on DPA425R-based forward converters for EV auxiliary systems operating under wide input variations and thermal stress.

Forward converters provide better transformer utilization, lower ripple, and improved efficiency compared with flyback converters for medium-power applications. Hence, this work proposes a DPA425R-based isolated forward converter for EV auxiliary systems. The objectives of this paper are:

- To design a compact isolated forward converter using DPA425R.
- To implement mathematical modelling for converter design.
- To evaluate converter performance under EV operating conditions.
- To compare the proposed converter with conventional flyback converters.

### Literature Review

The literature on integrated DC–DC converter solutions and EV-oriented power architectures highlights significant advancements in efficiency, compactness, and control strategies. Power Integrations' DPA Switch® family demonstrates a highly integrated approach to DC–DC conversion, combining control, switching, and protection features within a single IC, thereby reducing external component count and improving reliability [1]. Specifically, the DPA425R device extends these capabilities with high-frequency operation and wide input voltage support, making it suitable for automotive and industrial applications [2]. The broader DPA422–426 family further provides detailed design methodologies, including thermal management and protection mechanisms, which are essential for robust converter implementation [3]. Practical validation of these ICs is illustrated through design examples such as isolated flyback converters for 36–75 VDC inputs, offering insights into topology selection, magnetics design, and loop compensation [4]. Additionally, technical discussions on DPA Switch series controllers emphasize built-in features like current sensing, auto-restart, and fault protection, reinforcing their suitability for low-voltage DC–DC systems [5].

In the context of electric vehicle (EV) applications, isolated DC–DC converters play a critical role in on-board charging and auxiliary power supply systems. A PFC-based on-board charger utilizing an isolated full-bridge DC–DC converter demonstrates the importance of high efficiency and galvanic isolation in 48 V battery systems [6]. Industry-focused reports from on semi outline key requirements for 48 V to 12 V conversion in vehicle electrification, including high power density, thermal performance, and reliability under dynamic load conditions [7]. Comparative studies of isolated converter topologies provide a comprehensive evaluation of efficiency, cost, and scalability trade-offs, guiding optimal topology selection for EV powertrains [8]. Advanced control strategies such as model predictive control further enhance the performance of bidirectional isolated converters, particularly for vehicle-to-grid (V2G) applications [9]. Moreover, comprehensive reviews of DC–DC converters for EVs consolidate these developments, offering a broad perspective on emerging trends and technological challenges [10]. Beyond vehicle systems, recent research on multi-micro grid energy management highlights the integration of renewable energy sources and demand response strategies, indicating the growing importance of efficient power conversion in distributed energy systems [11].

## Methodology

The proposed converter operates from a 36–75 V DC input and provides a regulated 5 V isolated output at 30 W. The DPA425R IC integrates a 220 V MOSFET, PWM controller, soft-start, thermal shutdown, current limiting, and auto-restart protection.

A forward converter topology is selected due to its improved transformer utilization and lower output ripple compared with flyback converters. The converter consists of an input EMI filter, DPA425R switching stage, high-frequency transformer, rectifier stage, LC output filter, and optocoupler-based isolated feedback circuit.

## Mathematical Modeling

### Mathematical Modeling of Forward Converter

The proposed isolated forward converter operates using pulse-width modulation control. During the ON period of the switching cycle, energy is transferred directly from the transformer primary to the secondary winding. The output voltage of the forward converter can be expressed as:

$$V_o = D \times \frac{N_s}{N_p} \times V_{in}$$

where:

- $V_o$  = Output voltage
- $D$  = Duty cycle
- $N_s/N_p$  = Transformer turns ratio
- $V_{in}$  = Input voltage

The duty cycle is selected within the safe operating range of the DPA425R controller to avoid transformer core saturation and excessive switching stress.

### Output Inductor Design

The output inductor value is determined from the allowable ripple current:

$$L_o = \frac{V_o(1 - D)}{\Delta I_L \times f_s}$$

where:

- $L_o$  = Output inductance
- $\Delta I_L$  = Inductor ripple current
- $f_s$  = Switching frequency

For this design:

- Switching frequency = 300 kHz
- Output voltage = 5 V
- Output current = 6 A

- Ripple current = 20% of rated current

The calculated inductance ensures continuous conduction mode operation and reduced output ripple.

### Output Capacitor Design

The output capacitor is selected based on ripple voltage requirements:

$$C_o = \frac{\Delta I_L}{8f_s \Delta V_o}$$

where:

- $C_o$  = Output capacitance
- $\Delta V_o$  = Output voltage ripple

Low-ESR capacitors are selected to minimize ripple and improve transient response.

### Transformer Turns Ratio:

The transformer turns ratio is selected using:

$$\frac{N_s}{N_p} = \frac{V_o}{D \times V_{in(min)}}$$

This ensures proper voltage regulation over the complete input voltage range.

## Converter Design

The transformer turns ratio is selected to maintain stable regulation over the complete input range. Schottky diode rectification and low-ESR capacitors are used to minimize conduction losses and output ripple. Thermal vias and copper planes are incorporated in the PCB layout for improved heat dissipation.

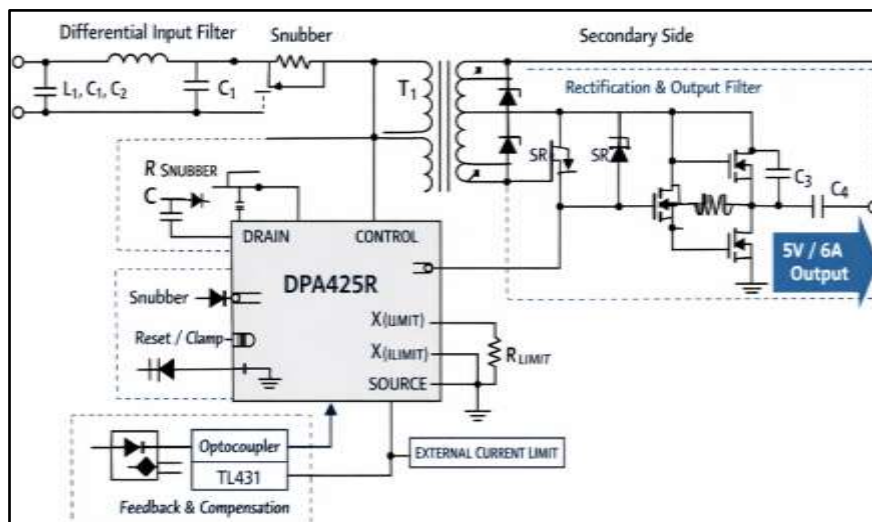

**Figure 1.** Proposed DPA425R based Isolated Forward Converter for EV Auxiliary Supply

## Results and Discussion

The proposed converter was simulated and experimentally validated under different operating conditions.

### Output Voltage Regulation

The converter maintained a regulated 5 V output with voltage variation within  $\pm 2\%$  across the complete input range. The output ripple remained below 50 mV due to the optimized LC output filter.

### Efficiency Analysis

The converter achieved a peak efficiency of approximately 88% at rated load. Efficiency remained above 84% for most operating conditions. Improved efficiency was obtained due to reduced switching losses and better transformer utilization in the forward topology.

### Protection and Thermal Performance

The DPA425R protection features operated effectively during overload and short-circuit conditions. Auto-restart and current limiting reduced component stress under fault conditions. Thermal analysis confirmed that the junction temperature remained within safe operating limits during full-load operation.

### Comparison with Existing Methods

**Table 1.** Comparison between conventional flyback and proposed forward.

Parameter	Flyback Converter	Proposed Forward Converter
Efficiency	78–82%	84–88%
Output Ripple	Higher	Lower
Transformer Stress	High	Moderate
Thermal Performance	Moderate	Improved
Component Count	Moderate	Reduced
Suitability for EV Auxiliary Loads	Limited	Highly Suitable

Compared with conventional flyback converters, the proposed forward converter demonstrates improved efficiency, lower ripple, enhanced thermal performance, and better suitability for medium-power EV auxiliary applications.

## Conclusion

An isolated forward DC–DC converter using the DPA425R integrated switcher IC has been successfully implemented for EV auxiliary applications. The converter operates over a 36–75 V DC input range and provides a regulated 5 V isolated output at 30 W. The proposed design achieved peak efficiency of approximately 88% with output voltage regulation within  $\pm 2\%$ . Experimental analysis confirmed reliable thermal performance, low ripple, and effective fault protection under overload and short-circuit conditions. Compared with conventional

flyback converters, the proposed forward converter demonstrated improved efficiency and reduced ripple, making it suitable for compact EV auxiliary power systems.

### Acknowledgement

I would like to express my sincere gratitude to Vi Microsystem for their invaluable support and guidance throughout my project. Their technical resources, expertise, and encouragement were instrumental in successfully completing this work. I truly appreciate the opportunity to collaborate with their team and thank them for helping me realize the objectives of my research. I would also like to express my sincere gratitude to my institution for providing the necessary facilities, resources, and continuous support to carry out this research work successfully.

### References

- Application of DPA-Switch series integrated controllers in low-voltage DC-DC converters.* (2024). <https://en.eeworld.com.cn/news/dygl/eic137655.html>
- C. S and M. R. Sindhu, "A PFC Based Onboard Battery Charger using Isolated Full-Bridge DC-DC Converter for Electric Vehicle Application," *2022 IEEE IAS Global Conference on Emerging Technologies (GlobConET)*, Arad, Romania, 2022, pp. 581-586 <https://doi.org/10.1109/GlobConET53749.2022.9872512>
- H. Bai, et al. (2023). Model predictive control of isolated bidirectional DC–DC converter for EV V2G applications. *IEEE Transactions on Industrial Informatics*.
- HosseinZad, Shayan and Mirzaei, Amin (2023) "A Comprehensive Review of DC-DC Converters for EV Applications," *Emirates Journal for Engineering Research*: Vol. 28: Iss.2, Article 4. <https://scholarworks.uaeu.ac.ae/ejer/vol28/iss2/4>
- J. Everts, et al. (2023). A comparison of five topologies for isolated DC-DC converters in EV powertrains. *IEEE Journal of Emerging and Selected Topics in Power Electronics*.
- Onsemi. (2025). *48 Volt–LV DC-DC converter for vehicle electrification* (Application note/solution brief). <https://www.onsemi.com/solutions/automotive/electric-and-hybrid-powertrain/48-v-12-v-dc-dc-converter>
- Power Integrations. (2024). *DER-96: 36–75 VDC input, isolated flyback converter using DPA423* (Design example report). Power Integrations.
- Power Integrations. (2024). *DPA422–426 DPA-Switch® family: Highly integrated DC-DC converter ICs for 16–75 VDC input* (Rev. S). Power Integrations.
- Power Integrations. (2024). *DPA425R – High-frequency integrated DC-DC converter IC (16–75 V)* (Product brief and datasheet). Power Integrations.
- Power Integrations. (2024). *DPA-Switch® highly integrated DC-DC converter ICs for 16–75 V input* (Product overview and family datasheet). Power Integrations.
- S. Satishkumar, V. Pramila, S. Rudhra, S. Vinod, & D. Lakshmi. (2025). Enhancing demand response and energy management in multi-microgrid systems with renewable energy sources. *Renewable Energy*, 253. <https://doi.org/10.1016/j.renene.2025.123490>